

THIS DRAWING & DESIGN IS THE PROPERTY OF
CRYSTAL INDUSTRIAL SYNDICATE PVT. LIMITED
 AND MUST NOT BE COPIED OR LENT WITHOUT
 THEIR PERMISSION IN WRITING.

REV NO	DETAILS	DATE	DRAWN/REV. BY	CHECKED BY	APPROVED BY
-	-	-	-	-	-

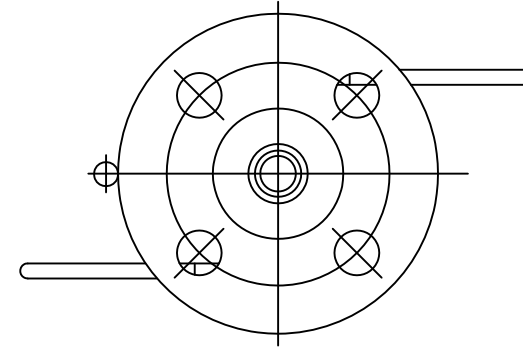

SECTION - 'A' - 'A'

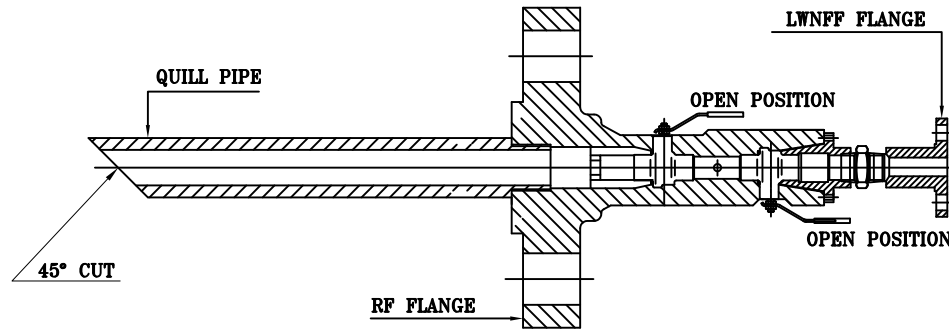
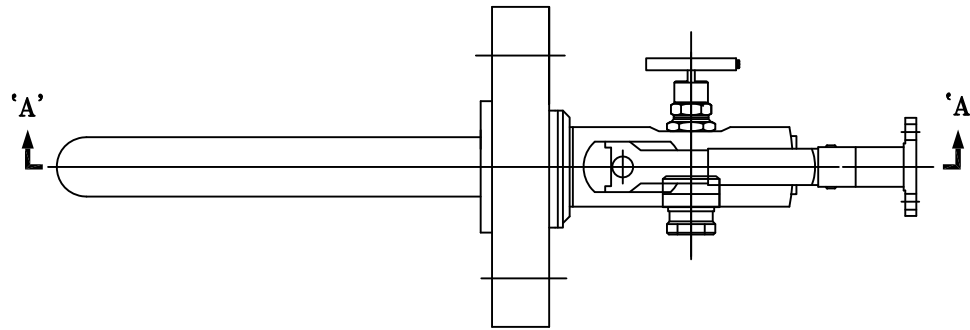

INJECTION QUILL

UNSPECIFIED TOLERANCE FOR
 MACHINING AS PER DIN 7168 CL. MEDIUM
 UNSPECIFIED TOLERANCE FOR WELDING
 AS PER DIN 8570 DEG. OF ACCURACY B.

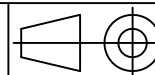

MANUFACTURER :-
CRYSTAL INDUSTRIAL SYNDICATE PVT. LTD
 -TALOJA WORKS

SURFACE FINISH SYMBOLS			
Symbol	Roughness (CLA) Microns		
	0.4	TO	0.8
	0.8	TO	1.6
	1.6	TO	4.0
	4.0	TO	8.0
	8.0	TO	25.0
	Machining after welding		
	Commercial finish Produce by Casting, Forging & Flame Cutting. Burrs & Projections removal.		
SCALE : -			

STAGE INSPECTION BY :
CERTIFIED FOR CONSTRUCTION SIGN. :
DATE :
DEPT. : -

INJECTION QUILL WITH DOUBLE BLOCK & BLEED VALVE			
CISPL JOB NO.	QTY	DRAWING NO.	REV.
-	-	-	-